



# ENVIRONMENTAL HEALTH AND SAFETY

## FIRE SPRINKLER SYSTEM STANDARD

---

Environmental Health and Safety | University Health Services Suite 002 | Stillwater, OK 74078

(405) 744-7241 | [www.ehs.okstate.edu](http://www.ehs.okstate.edu)

*Reviewed and Revised April 2026*

# Status

<b>Contact(s)</b>	<b>Implementation Date</b>	<b>Comments</b>
Gerald Petre, EHS	June 2016	Review and update
Gerald Petre, EHS	September 2017	Review and update
Gerald Petre, EHS	September 2018	Minor spacing updates
Gerald Petre, EHS	April 2024	Clarified the requirements for Exterior Fire Department connections, installation of control valves, test valves and flow switches and the requirement for the University Fire Marshal to be present during system flushing and hydrostatic testing.
Gerald Petre and Alex Christy, EHS	April 2025	Minor grammar and spacing updates. Edited for clarity.
Gerald Petre, EHS	April 2026	Clarified what is required to get an exception to chrome plates sprinkler head requirement. Made minor spacing changes and corrected some wrong size font.

**Table of Contents**

**Status.....2**  
**A: INTRODUCTION..... 4**  
**B: MATERIALS..... 4**  
**C: INSTALLATION AND ACCEPTANCE.....6**

# A: INTRODUCTION

The information included in this standard is intended to identify specific items required by Oklahoma State University (OSU) in the design and structure of fire sprinkler systems on the main campus in Stillwater, Oklahoma. Items of normal, code, industry or standard construction practice are not included in this document.

## **CONTRACTOR QUALIFICATIONS AND REQUIREMENTS**

A minimum of five years specialized experience in sprinkler system installation is required from contractors employed to perform work on campus. Project foreman shall have a minimum of three years of experience.

Shop drawings must be submitted to Long Range Facilities Planning (LRFP) or Facilities Management (FM), who will communicate with a representative of the OSU Environmental Health and Safety (EHS) department for approval prior to installation.

## **DESIGN CRITERIA**

Sprinkler systems shall be designed to a minimum category of "Ordinary Hazard 1." Light hazard systems are not permitted in OSU buildings.

# B: MATERIALS

## **ABOVE GROUND PIPING**

All above ground piping must be Schedule 40 black pipe without reducing bushings. No CPVC piping or fittings will be allowed.

## **SPRINKLERS**

Sprinklers exposed to public view shall be chrome plated, semi-recessed type, either Star Sprinkler Corp. or an approved equivalent. Any deviation must be approved by the University Architect and the University Fire Marshal.

Flexible sprinkler assemblies shall consist of wire-braided hose and shall be Underwriter's Laboratories (UL) listed and FM approved. The flexible metal units are not authorized.

All sprinkler heads shall be installed in the center of ceiling tiles.

## **SPARE SPRINKLER HEADS**

Six spare sprinkler heads and a sprinkler wrench for each temperature and style used shall be provided inside a metal box installed adjacent to the main sprinkler valve in an accessible location not more than 5 ½ feet above floor level.

A list of sprinklers installed shall be posted in the sprinkler cabinet. The list should include the manufacturer, model, orifice, deflector type, thermal sensitivity, pressure rating and specific location of each sprinkler head in the building.

## **VALVE CABINETS**

Valve cabinets shall be Potter Roemer Series 1800 or an approved equivalent that is fully recessed steel with a white prime coat finish.

## **HOSE VALVES**

Hose valves shall be Potter - Roemer, Elkhart Brass, or an approved equivalent, single 2 ½" polished chrome-plated hose valve with a 1 ½" - 2 ½" adapter and a 1 ½" cap and chain. The 2 ½" valve and adapter shall be provided with National Standard Hose Threads. Turn the outlet to the corridor and cover any exposed pipe with a chrome sleeve. A 1" minimum clearance between the hand wheel and cabinet is required.

## **FLOW SWITCHES**

The flow switches must be Potter Electric Signal Co. Model VSR series. NO SUBSTITUTES. All flow switches shall be set with a time delay between 45 and 60 seconds. Label all test valves with a sign that says "Test Valve - Keep Closed" in white letters on a red background. All test valves shall drain to the outside of the building unless otherwise approved by the Authority Having Jurisdiction (AHJ).

## **EXTERIOR FIRE DEPARTMENT CONNECTION (FDC)**

The FDC shall be a sidewall or flush mount wall type within 3' of a stable walking surface installed 3' to 4' above exterior grade, polished chrome-plated, escutcheon plate with "Automatic Sprinklers" cast in plate, and individual clappers on each inlet connection. Each inlet shall have a female switch with pin lugs, 2 ½ inch National Standard Hose threads, gasket, and KNOX-type cap. Piping shall be pitched to an automatic ball drop inside the building or to an approved exterior concrete valve pit with access cover.

If a stable walking surface is not available, the FDC will be a remote installation.

There shall be a fire hydrant located within 150 feet of the FDC and shall be on the same side of the road as the FDC.

Storz connections are not allowed on the Stillwater Campus.

## **LOCKING FIRE DEPARTMENT CONNECTION CAPS**

A KNOX® locking cap shall be required on all fire department connections for water-based fire protection systems. All KNOX® caps shall be a bright stainless steel or a polished chrome-like stainless steel finish. All KNOX® locking caps shall be keyed to the current Knox key wrenches for the local fire department having jurisdiction.

## **CONTROL VALVES**

All control valves shall be Stockholm, Traverse City, or an approved equivalent, 175 lbs. test crank type with butterfly valves, indicator, tamper switch and lockable in the open position with a padlock.

## **EXTERIOR POST INDICATOR VALVE (PIV)**

The PIV shall be Demco, Incorporated, or an approved equivalent, painted with two coats of Rust-Oleum No. 1565, International Red, Quick Dry Gloss. NO SUBSTITUTES. PIV shall be installed so the top of the post is 32" to 40" above final grade.

### **PIV Electrical Supervisory Switch**

The PIV electrical supervisory switch shall be a Potter Electric Signal Co., Model PIVS - U. NO SUBSTITUTES. The switch shall be installed on post indicator and control valves so that a supervisory signal will be registered on the designated circuit of the fire alarm system if the valve is closed more than 1 ½ turns from full open position. The switch shall be wired so when it is in the trouble position, it will not prevent the sounding of the fire alarm on circuit.

If the main sprinkler riser can be DIRECTLY accessed from the exterior of the building, the PIV may be eliminated with the AHJ's approval.

## **WATER FLOW ALARM**

An electronic horn/strobe shall be installed on the exterior of the building above the FDC in a location approved by the AHJ.

## **AUXILIARY / INSPECTORS TEST DRAINS**

All auxiliary and inspector test drains shall be piped to the exterior of the building. Hose bibs are not allowed.

# **C: INSTALLATION AND ACCEPTANCE**

The sprinkler system shall be zoned into a minimum of two zones per floor with sectional valves, water flow switches, and tamper switches. Valves shall be capable of locking in open position. For exceptions, seek approval from the AHJ.

**All control valves, test valves and flow switches shall be installed in an easily accessible location between 4' and 6' above the finished floor.**

No sprinkler heads or sprinkler piping shall be installed in or routed through designated IT spaces.

Underground piping shall be inspected for compliance by representatives of Long Range Facilities Planning, Facilities Management and Environmental Health and Safety.

Underground piping shall be thoroughly flushed in accordance with NFPA 13 section 10.10.2.1, before piping is connected to the building sprinkler system. Flushing shall be witnessed by the University Fire Marshal and representatives of Long Range Facilities Planning, Facilities Management and Environmental Health and Safety. Provide 48 hours prior notice.

Prior to placing piping in service, a flush of the entire system is required to remove foreign substances. Continue flushing until water is clear and check to ensure that debris has not clogged sprinklers. This flushing shall be witnessed by the University Fire Marshal and representatives of Long Range Facilities Planning, Facilities Management and Environmental Health and Safety. Provide 48 hours prior notice.

Test the entire system hydrostatically at 200 psi or 50 psi over operating pressure for a period of two hours. (Prior partial tests will not be recognized for acceptance purposes.) The test shall be scheduled 48 hours in advance and must be completed prior to pre-final inspection. The test shall be witnessed by the University Fire Marshal and representatives of Long Range Facilities Planning, Facilities Management and Environmental Health and Safety. Leaks shall be corrected and re-tests made until the system is deemed acceptable. Record results on a standard NFPA #13 test form.

Prior to pre-final inspection of the system, the contractor shall furnish two copies (one print and one PDF) of a complete set of permanent plans showing the entire system as installed (as built). Plans shall show all pipe sizes, runs, valves, head temperatures, head counts, etc. and shall be made in a neat and legible manner suitable for use as permanent record for future maintenance of the system. No acceptance or inspection will be made without plans. Pre-final tests shall include testing of all water flow and tamper switches.

The installing contractor shall identify a hydraulically designed sprinkler system with an engraved or stamped metal sign secured with corrosion resistant wire, chain, or other approved means. Such signs shall be placed at the alarm valve, dry pipe valve, pre-action valve, or deluge valve supplying the corresponding hydraulically designed area in accordance with NFPA 13.

## NFPA 13 FIRE SPRINKLER RISER DETAIL

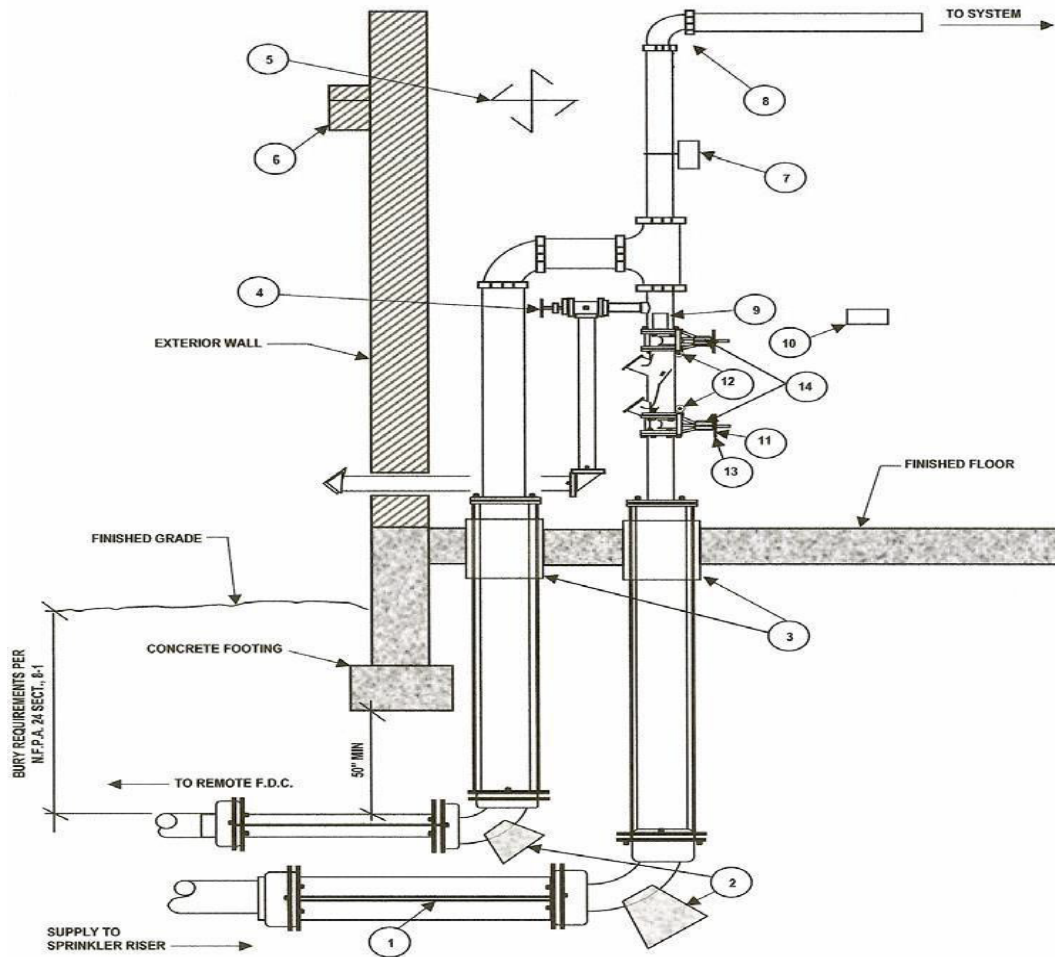

### Riser Key Notes

1. 5' 0" ductile iron stub-out feed
2. Thrust block
3. Sleeve through floor
4. 2" main drain with angle valve
5. 4-way sway brace
6. Exterior horn/strobe
7. Flow switch
8. Grooved elbow
9. Hydraulic design data plate
10. Spare sprinkler box
11. Double check valve assy
12. 300 PSI pressure gauges
13. Listed system control valve with tamper
14. Tamper switch

### Notes

1. Fire sprinkler system to be electronically monitored by UL or FM listed central station for flow, tamper and trouble.
2. Provide A 3'-0" clearance around fire sprinkler riser for minimum access.
3. All valves shall be a max of 6'-0" A.F.F.